

**IT** - SUN R1E - F. 433.920 MHz  
Ricevitore radio 1 canale





**GB** - SUN R1E - F. 433.920 MHz  
Reciver radio 1 channel

**Programmazione**

**1) - Memorizzazione radiocomando:**

Premere e rilasciare il pulsante [ P ], il Led [ L ] lampeggia per 10" indicando il modo di funzionamento, trasmettere ora con il radiocomando, il Led [ L ] lampeggia velocemente per indicare operazione eseguita correttamente.  
Attendere l'uscita dalla programmazione, per memorizzare ulteriori radiocomandi ripetere dal punto N.1.

**2) - Modo funzionamento Relè:**

Modo impulsivo 1 lampeggio veloce.   
Modo passo-passo 2 lampeggi veloci.   
Modo timer 30" 3 lampeggi veloci.   
Modo timer 3' 4 lampeggi veloci. 

**3) - Modifica modo funzionamento Relè:**

Premere e rilasciare il pulsante [ P ], il Led [ L ] lampeggia per 10" indicando il modo di funzionamento, per modificarlo premere nuovamente [ P ], ogni pressione modifica lo stato in modo ciclico, come indicato al punto N.2, attendere l'uscita dalla programmazione.

**4) - Cancellazione di tutti i radiocomandi:**





Premere e mantener premuto [ P ] per 10" il led [ L ] comincia a lampeggiare per 5", durante questo intervallo premere e rilasciare nuovamente [ P ], il ed [ L ] rimane fisso per 3" per indicare il reset totale della memoria.

**Set-Up**

**1) - Setting the remote control:**

Press and release the [ P ] key , the Led [ L ] will blink for 10 seconds indicating the mode , transmit now using your remote, the Led [ L ] will start blinking faster , this indicates that the operation was performed successfully.  
Now wait for the programming to be done , to memorize new remotes repeat from step N.1

**2) - Relè function mode:**

Impulsive mode 1 fast blink.   
Step by step mode 2 fast blinks.   
30" timer mode 3 fast blinks.   
3' timer mode 4 fast blinks. 

**3) - Relè mode settings:**

Press and release the [ P ] key , the Led [ L ] will start blinking for 10 seconds indicating the current settings , to change it press the [ P ] key again , every time you press the [ P ] you change the function mode in a cycle like shown in point N.2, wait for exiting the programming mode.

**4) - Deleting all the remotes control:**

Press and keep pressing the [ P ] key for 10 seconds the Led [ L ] will start blinking for 5 seconds, during this 5 seconds press the [ P ] key and release it , the led [ L ] will shine for 3 seconds, this will indicate that the memory has been erased completely.

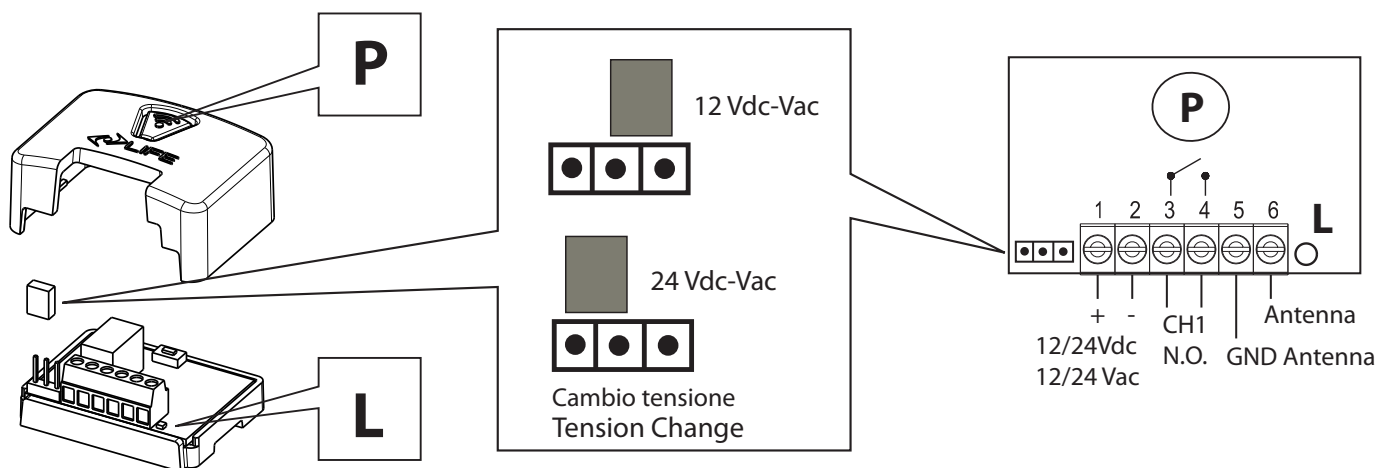

Alimentazione Power Supply	N° Canali N° Channel	Contatto Relè Relè Contact	Frequenza Frequency	Memoria codici Memory codes	Assorbimento Absorption	Temperatura Temperature	IP
12/24 Vac-Vdc	1 N.O.	1A Max 50V	433,92 MHz	30 Tx	40 mA Max	-20/+70 °C	30



# F - SUN R1E - F. 433.920 MHz





## Ricevitore radio 1 canale

### La programmation

#### 1) - Mémorisation de télécommande radio:

Appuyer et relâcher le bouton [ P ], la Led [ L ] clignote pendant 10 ", indiquant le mode de fonctionnement, Transmettez avec la télécommande radio, la Led [ L ] clignote rapidement pour indiquer que l'opération a été effectuée. Attendez que le mode programme soit désactivé, pour mémoriser une nouvelle télécommande répétez la procédure.

#### 2) - Fonctionnement du Relais:

IMPULSIF 1 Quick FLASH   
 SÉQUENTIEL 2 clignotements rapides.   
 TEMPORISÉ 30 " 3 clignotements rapides.   
 TEMPORISÉ 3 ' 4 clignotements rapides. 

#### 3) - Modifier le mode operation Relais:

Appuyer et relâcher le bouton [ P ], le Led [ L ] clignote pendant 10", indiquant le mode de fonctionnement, pour le changer appuyez sur [ P ], chaque fois change le mode de fonctionnement cycliquement comme indiqué au chapitre N.2, attendez que le mode programme soit désactivé.

#### 4) - Annulation de toutes les télécommande:

Appuyez sur le bouton [ P ] pendant 10 ", la Led [ L ] commence à clignoter pendant 5", pendant cette période, appuyez et relâchez le bouton [ P ] à nouveau, et la Led [ L ] reste allumée pendant 3 "pour indiquer Supprimer, Nettoyer et Réinitialiser de la mémoire.

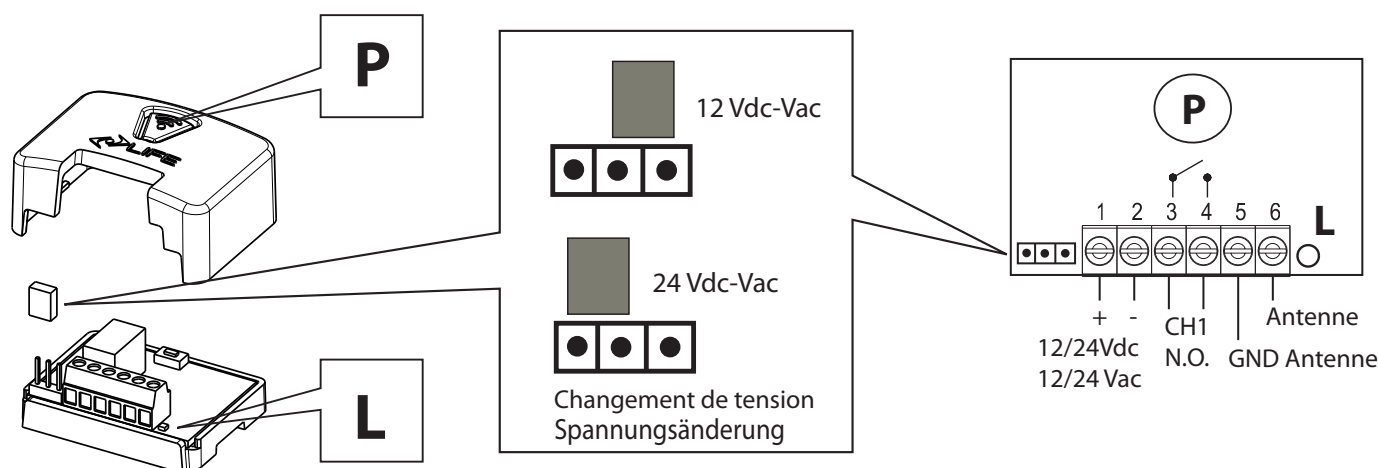

# D - SUN R1E - F. 433.920 MHz





## Funkempfänger Kanal1

### Programmierung

#### 1) - Fernsteuerung Speicherung:

Drücken Sie die Taste [ P ] und lassen Sie sie wieder los. Die Led [ L ] blinkt für 10 "die Betriebsart anzeigen, jetzt übermitteln mit der Funksteuerung, blinkt die Led [ L ] schnell für zeigt an, dass die Operation korrekt ausgeführt wurde. Warten Sie auf den Ausgang von der Programmierung, um zu speichern weitere Funkbefehle, wiederholen sich ab Punkt N.1.

#### 2) - Relè Funktionsweise:

Impulsiv Modus 1 schnell Blinksignal.   
 Schritt Modus 2 schnelle Blinksignale   
 Timer 30" Modus 3 schnelle Blinksignale.   
 Timer 3' Modus 4 schnell Blinksignale. 

#### 3) - Relè Funktionsweise Umänderung:

Drücken Sie die [ P ]-Taste und lassen Sie sie wieder los, die LED [L] blinkt für 10 ", indem Sie den Betriebsmodus anzeigen. Um sie erneut zu ändern, drücken Sie erneut [ P ], und jedes. Drücken ändert den Status zyklisch, wie in Punkt N.2 angegeben, warten die Ausgabe aus der Programmierung.

#### 4) - Alle Funksteuerungen löschen:

Drücken und halten Sie [ P ] für 10 ", die [ L ]-Led beginnt während dieses Intervalls für 5" zu blinken, drücken Sie erneut [ P ], und [ L ] bleibt für 3 " geben Sie den Totalreset der Speicherung an

Source courant Versorgung	N° Canaux N° Kanäle	Contact Relais Relè Kontakt	Fréquence Frequenz	Mémoire de code Code Steuerung	Absorption Absorption	Température Temperatur	IP
12/24 Vac-Vdc	1 N.O.	1A Max 50V	433,92 MHz	30 Tx	40 mA Max	-20/+70 °C	30



**IT** - **SUN R1E - F. 433.920 MHz**  
Ricevitore radio 1 canale

**GB** - **SUN R1E - F. 433.920 MHz**  
Reciver radio 1 channel





**Programmazione**

**1) - Memorizzazione radiocomando:**

Premere e rilasciare il pulsante [ P ], il Led [ L ] lampeggia per 10" indicando il modo di funzionamento, trasmettere ora con il radiocomando, il Led [ L ] lampeggia velocemente per indicare operazione eseguita correttamente.

Attendere l'uscita dalla programmazione, per memorizzare ulteriori radiocomandi ripetere dal punto N.1.

**2) - Modo funzionamento Relè:**

Modo impulsivo 1 lampeggio veloce.   
 Modo passo-passo 2 lampeggi veloci.   
 Modo timer 30" 3 lampeggi veloci.   
 Modo timer 3' 4 lampeggi veloci. 

**3) - Modifica modo funzionamento Relè:**

Premere e rilasciare il pulsante [ P ], il Led [ L ] lampeggia per 10" indicando il modo di funzionamento, per modificarlo premere nuovamente [ P ], ogni pressione modifica lo stato in modo ciclico, come indicato al punto N.2, attendere l'uscita dalla programmazione.

**4) - Cancellazione di tutti i radiocomandi:**

Premere e mantener premuto [ P ] per 10" il led [ L ] comincia a lampeggiare per 5", durante questo intervallo premere e rilasciare nuovamente [ P ], il ed [ L ] rimane fisso per 3" per indicare il reset totale della memoria.





**Set-Up**

**1) - Setting the remote control:**

Press and release the [ P ] key , the Led [ L ] will blink for 10 seconds indicating the mode , transmit now using your remote, the Led [ L ] will start blinking faster , this indicates that the operation was performed successfully.

Now wait for the programming to be done , to memorize new remotes repeat from step N.1

**2) - Relè function mode:**

Impulsive mode 1 fast blink.   
 Step by step mode 2 fast blinks.   
 30" timer mode 3 fast blinks.   
 3' timer mode 4 fast blinks. 

**3) - Relè mode settings:**

Press and release the [ P ] key , the Led [ L ] will start blinking for 10 seconds indicating the current settings , to change it press the [ P ] key again , every time you press the [ P ] you change the function mode in a cycle like shown in point N.2, wait for exiting the programming mode.

**4) - Deleting all the remotes control:**

Press and keep pressing the [ P ] key for 10 seconds the Led [ L ] will start blinking for 5 seconds, during this 5 seconds press the [ P ] key and release it , the led [ L ] will shine for 3 seconds, this will indicate that the memory has been erased completely.

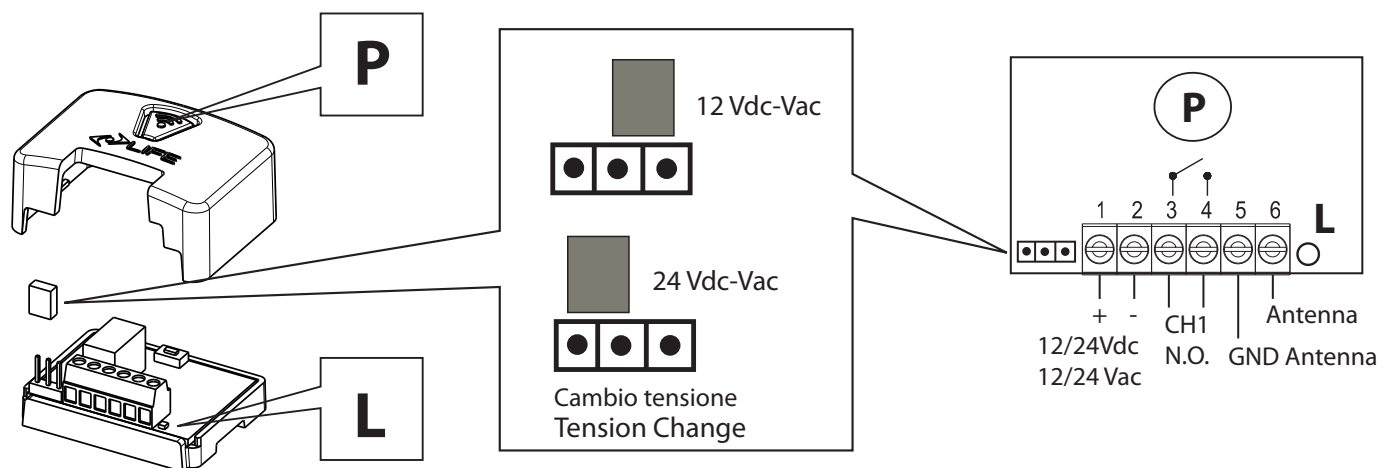

Alimentazione Power Supply	N° Canali N° Channel	Contatto Relè Relè Contact	Frequenza Frequency	Memoria codici Memory codes	Assorbimento Absorption	Temperatura Temperature	IP
12/24 Vac-Vdc	1 N.O.	1A Max 50V	433,92 MHz	30 Tx	40 mA Max	-20/+70 °C	30



# F - SUN R1E - F. 433.920 MHz





## Ricevitore radio 1 canale

### La programmation

#### 1) - Mémorisation de télécommande radio:

Appuyer et relâcher le bouton [ P ], la Led [ L ] clignote pendant 10 ", indiquant le mode de fonctionnement, Transmettez avec la télécommande radio, la Led [ L ] clignote rapidement pour indiquer que l'opération a été effectuée. Attendez que le mode programme soit désactivé, pour mémoriser une nouvelle télécommande répétez la procédure.

#### 2) - Fonctionnement du Relais:

IMPULSIF 1 Quick FLASH   
 SÉQUENTIEL 2 clignotements rapides.   
 TEMPORISÉ 30 " 3 clignotements rapides.   
 TEMPORISÉ 3 ' 4 clignotements rapides. 

#### 3) - Modifier le mode operation Relais:

Appuyer et relâcher le bouton [ P ], le Led [ L ] clignote pendant 10", indiquant le mode de fonctionnement, pour le changer appuyez sur [ P ], chaque fois change le mode de fonctionnement cycliquement comme indiqué au chapitre N.2, attendez que le mode programme soit désactivé.

#### 4) - Annulation de toutes les télécommande:

Appuyez sur le bouton [ P ] pendant 10 ", la Led [ L ] commence à clignoter pendant 5", pendant cette période, appuyez et relâchez le bouton [ P ] à nouveau, et la Led [ L ] reste allumée pendant 3 "pour indiquer Supprimer, Nettoyer et Réinitialiser de la mémoire.

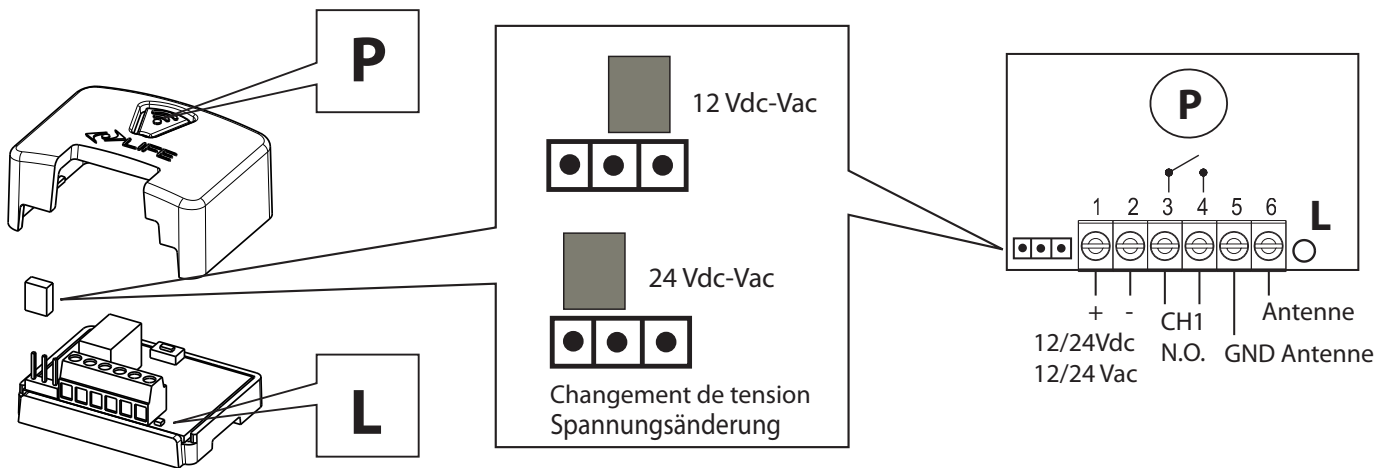

# D - SUN R1E - F. 433.920 MHz



## Funkempfänger Kanal1

### Programmierung

#### 1) - Fernsteuerung Speicherung:

Drücken Sie die Taste [ P ] und lassen Sie sie wieder los. Die Led [ L ] blinkt für 10 "die Betriebsart anzeigen, jetzt übermitteln mit der Funksteuerung, blinkt die Led [ L ] schnell für zeigt an, dass die Operation korrekt ausgeführt wurde. Warten Sie auf den Ausgang von der Programmierung, um zu speichern weitere Funkbefehle, wiederholen sich ab Punkt N.1.

#### 2) - Relè Funktionsweise:

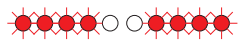
Impulsiv Modus 1 schnell Blinksignal.   
 Schritt Modus 2 schnelle Blinksignale   
 Timer 30" Modus 3 schnelle Blinksignale.   
 Timer 3' Modus 4 schnell Blinksignale. 

#### 3) - Relè Funktionsweise Umänderung:

Drücken Sie die [ P ]-Taste und lassen Sie sie wieder los, die LED [L] blinkt für 10 ", indem Sie den Betriebsmodus anzeigen. Um sie erneut zu ändern, drücken Sie erneut [ P ], und jedes. Drücken ändert den Status zyklisch, wie in Punkt N.2 angegeben, warten die Ausgabe aus der Programmierung.

#### 4) - Alle Funksteuerungen löschen:

Drücken und halten Sie [ P ] für 10 ", die [ L ]-Led beginnt während dieses Intervalls für 5" zu blinken, drücken Sie erneut [ P ], und [ L ] bleibt für 3 " geben Sie den Totalreset der Speicherung an

Source courant Versorgung	N° Canaux N° Kanäle	Contact Relais Relè Kontakt	Fréquence Frequenz	Mémoire de code Code Steuerung	Absorption Absorption	Température Temperatur	IP
12/24 Vac-Vdc	1 N.O.	1A Max 50V	433,92 MHz	30 Tx	40 mA Max	-20/+70 °C	30

